

PLAN VIEW

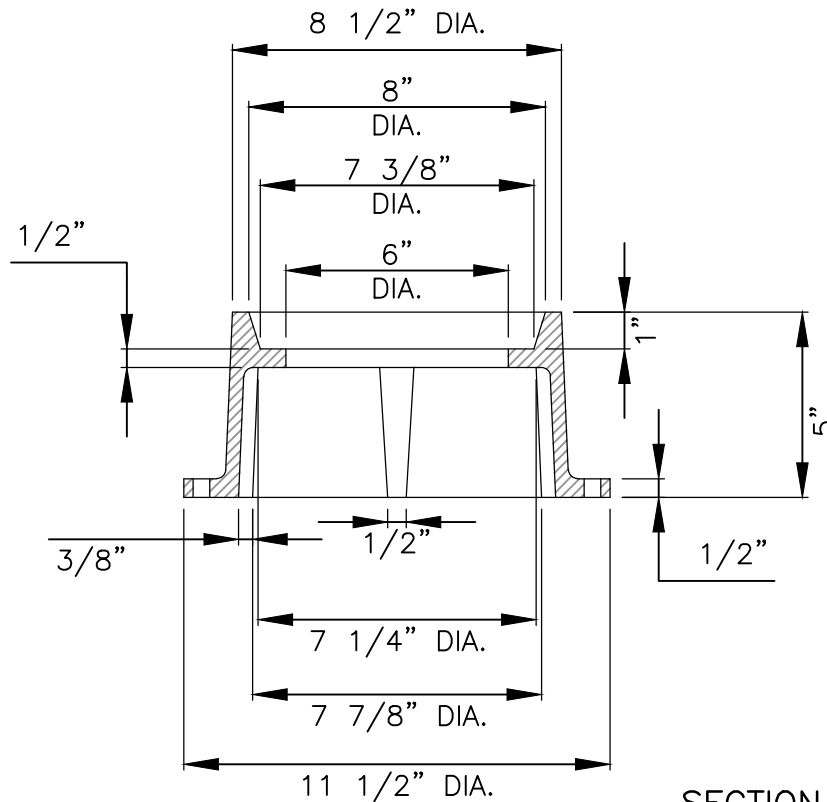

SECTION A-A

NOTE:

1. MATERIALS SHALL BE GRAY CAST IRON, ASTM A48, GRADE 30B.
2. THE MANUFACTURER'S IDENTIFICATION AND CASTING NUMBER AND THE COUNTRY WHERE CAST, SHALL BE DISTINCTLY CAST ONTO EACH RING.
3. DRAFT AND SHRINKAGE ALLOWANCE SHALL BE IN ACCORDANCE WITH NORMAL FOUNDRY PRACTICE.
4. FINISH BY REMOVING FINS AND FLASHING; PAINT WITH BLACK ASPHALT COATING.
5. WEIGHT: APPROXIMATELY 23 LBS.



TRAVIS COUNTY WATER CONTROL AND
IMPROVEMENT DISTRICT No. 17
STANDARD DETAILS

ADOPTED:

03/01/2016

VALVE BOX CASTING COLLAR
(PAVING RING)

THE ARCHITECT/ENGINEER ASSUMES
RESPONSIBILITY FOR APPROPRIATE
USE OF THIS STANDARD.

DETAIL NO.

W/WW12